

Name:

Product code: **2482**

Riser D300 H150 AQ



Product description

The riser D300 H150 AQ is a put-on cylindrical extension for the distribution box AQR, collection box AQZ. It is made of high-density polyethylene HDPE, by plastic injection. It is characterized by a light, transversely and longitudinally ribbed structure. Included with the riser there are four assembly screws and a gasket whose task is to seal the connection box - riser or riser - riser.

The use of the riser allows to install a box at a greater depth. The assembly of the riser is done by putting it on and then screwing four INOX screws. The active height of the riser is 150 mm.

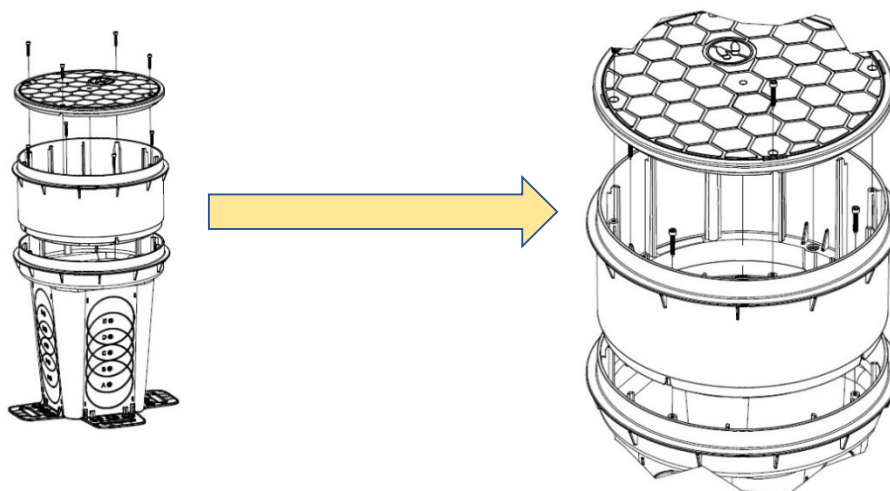
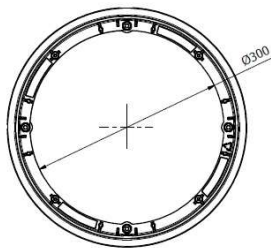
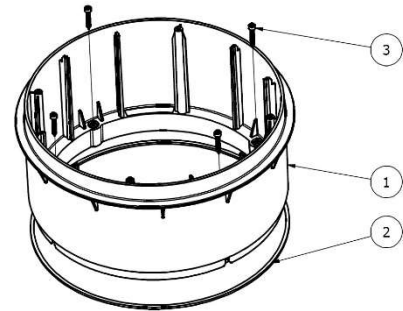
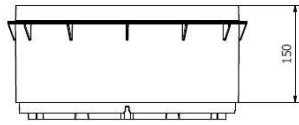

Figure 1: Riser D300 H150 AQ – assembly onto the box

○ Product specifications

| Length [mm] | Width [mm] | Height [mm] | Weight [kg] | Product code |
|-------------|------------|-------------|-------------|--------------|
| 370 | 370 | 175 | 1 | 2482 |



| Riser D300 H150 AQ | | |
|--------------------|------------|-----------------|
| Number | Name | Quantity [pcs.] |
| 1 | Riser body | 1 |
| 2 | Gasket | 1 |
| 3 | INOX screw | 4 |

○ Installation conditions

The riser is mounted directly onto the box or other riser. Check fit before assembly. Screw the riser using four INOX screws.

○ Warranty

The Manufacturer guarantees the delivery of devices free from defects. In case of detecting a manufacturing defect in the device, which has been confirmed by the TYCNER's Aftersales Department, the device will be repaired free of charge or the defective components will be replaced with new ones. The Manufacturer provides a **three-year warranty** for the device, counted from the date of sale.

The Manufacturer allows the installation of up to **five risers** on the box AQR or AQZ. The use of more risers and other than the original AQUABIN risers will void the warranty.

○ Related accessories

The riser can be mounted together with the distribution box AQR or collection box AQZ.

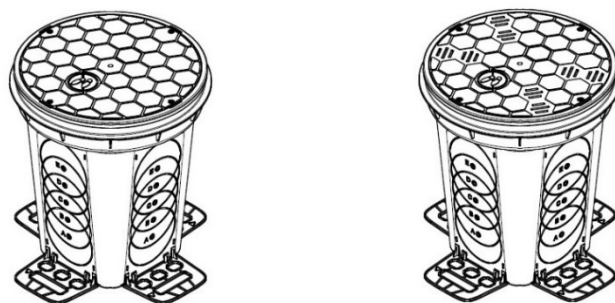

Figure 2: Distribution box D300 AQR (product code **2480**) – on the left, Collection box D300 AQZ (product code **2481**) – on the right