

Collection box D300 AQZ



Product description

The collection box D300 AQZ is a device responsible for aeration of wastewater in the infiltration drainage or biological bed. It also performs the service function of the bed. The box can also be used to infiltrate rainwater or perform a technical function in various types of systems.

The collection box AQZ is a monolithic cylinder with a height of 410 mm and a manhole diameter of 300 mm, made of high-density polyethylene HDPE, by plastic injection. The box is equipped with a $\varnothing 300$ mm perforated cover. In the box, up to four inlets for infiltration bed lines can be made. The height of the outlets has been defined on the box walls.

We install screwed risers made of polyethylene onto the manholes. With each box, three gaskets are provided for mounting in the sockets on the box. The sockets are blinded. They can be cut out with a knife or a standard holesaw.

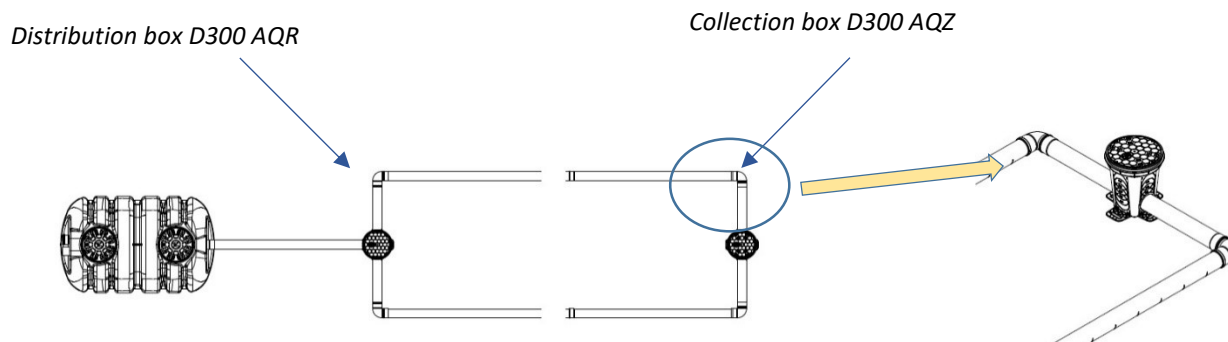
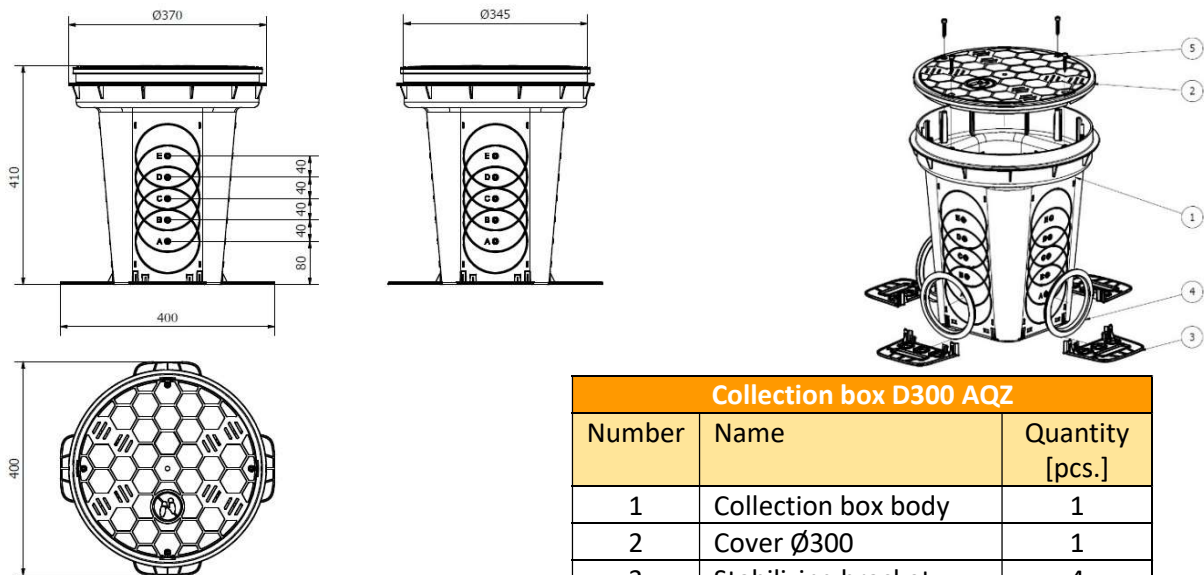

Figure 1: Collection box D300 AQZ – location in the drainage bed

Product specifications

Length [mm]	Width [mm]	Height [mm]	Weight [kg]	Product code
400	400	410	3	2481



Collection box D300 AQZ		
Number	Name	Quantity [pcs.]
1	Collection box body	1
2	Cover $\varnothing 300$	1
3	Stabilizing bracket	4
4	Gasket $\varnothing 110$ [mm]	3
5	INOX screw	4

Installation conditions

The collection box is to be installed directly in the ground. Before installation, cut out the outlet holes and then install the gaskets. Stabilizing brackets should be mounted with a latch in dedicated sockets located in the box body. The purpose of the brackets is to stabilize the box in the excavation and to anchor it in the ground.

Warranty

The Manufacturer guarantees the delivery of devices free from defects. In case of detecting a manufacturing defect in the device, which has been confirmed by the TYCNER's Aftersales Department, the device will be repaired free of charge or the defective components will be replaced with new ones. The Manufacturer provides a **three-year warranty** for the device, counted from the date of sale.

Related accessories

In case of installing the box at a greater depth, it is necessary to extend the inspection manhole. Dedicated RISERS D300 H150 AQ are used for this purpose. The active height of the riser is 150 mm, it is screwed with four screws. The Manufacturer allows the installation of a maximum of **five risers** per box. The use of more risers and other than the original AQUABIN risers with the collection box AQZ results in the loss of the warranty.

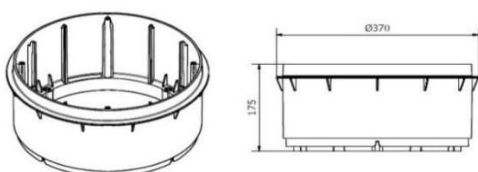

Figure 2: Riser D300 H150 AQ

(Product code **2482**)